



WS002 Series



Shenzhen Surmountor Lighting Co., LTD

✉ E-mail: sales@surmountor.com

☎ Tel: +86-0755-2792-6119/2792-6326

📍 Add: 2/F Building D Yonghengxin Industrial Park NO.5
Furui Road, Fuyong Town Shenzhen Guangdong China

1.Product Parameter

| Model | WS002-TD | WS002-PIR | WS002-DOOR/DOOR2 | WS002-RE | WS002-IRE |
|----------------------------|---|-----------|------------------|---|-----------|
| Communication Distance | < 15 meters | | | | |
| Carrier Frequency | 433.92 MHz | | | | |
| Transmitting Power | +10dBm | | | —— | |
| Receiving Sensitivity | —— | | | -109dBm | |
| Input Voltage | DC5V | | | DC12-24V | |
| Load Current | —— | | | | 6A MAX |
| Matching Time | Each pair matches successfully in 6 seconds, the time will automatically continue | | | | |
| Maximum Number of Pairings | —— | | | Eight, in first-in, first-out order | |
| Tuning Time | —— | | | 3 seconds (With WS002-TD supports dimming only) | |
| Time Delay Time | —— | | | 30 seconds (With WS002-PIR support only) | |
| Magnetic Sensing Distance | —— | | 1-1.5CM | —— | |
| Sensing Distance | —— | 3 meters | | —— | |

2. Usage Method

01. Pairing

| Step | Receive | Launch |
|------|--|---|
| 1 | Press the pairing button to enter the pairing mode with the blue lights on | × |
| 2 | × | Press the button on the back of the to-be-paired launch panel |
| 3 | When pairing successfully, light strip and blue light will flash | × |

02. Exit the pairing and receive any transmitter switching signal

| Step | Receive | Launch |
|------|---------|--|
| 1 | × | Transmitting switching or dimming signal |

03. Clear the pair

| Step | Receive | Launch |
|------|--|--------|
| 1 | Long press the matching button for 3 seconds, and the light strip and blue light flash off | × |

04. Switch / dimming

When matching successfully following the above steps, then lamp could be dimmed and switched.

05. Transmitter panel indicator light

| | |
|----------------------------|------------------|
| Launching | Blue light on |
| Charging | Red light on |
| Fully charged | Green light on |
| Lack of electricity | Blue light flash |

3. Wiring Diagram

01. WS002-TD

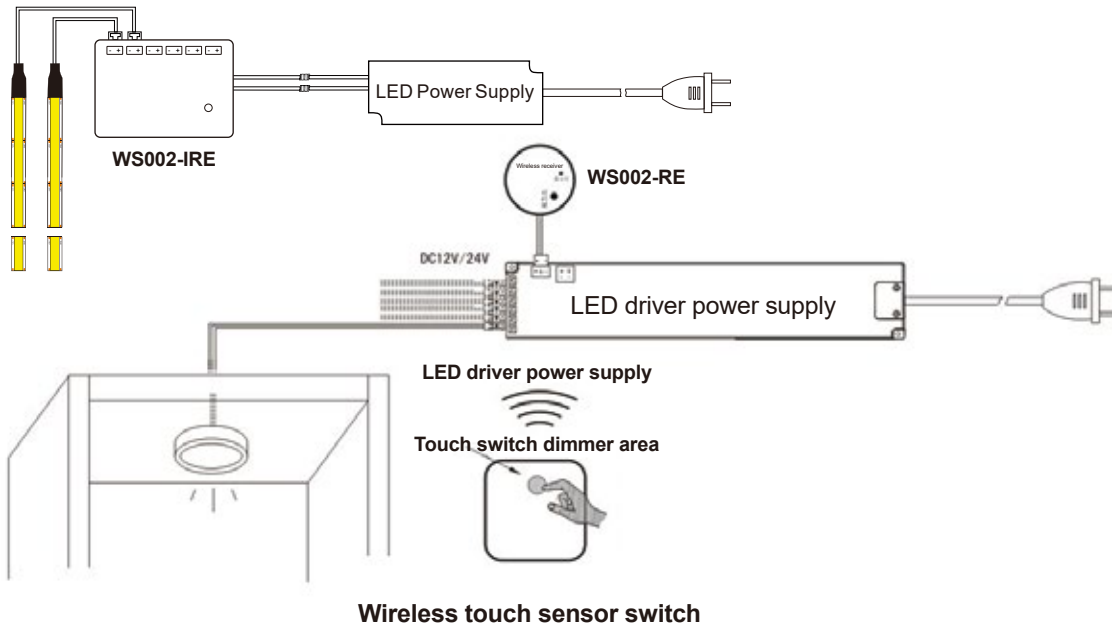

1. Working principle of wireless touch dimming remote control: This product is a unique Class III insulation sensor switch designed based on 433.92 MHz radio applications.
2. Touch switch dimmer area function: When a finger touch is detected within the touch switch dimming range, the remote control will act accordingly. A short touch (<0.5 seconds) turns the lights on or off. A long touch (>0.5 seconds) to adjust the brightness of LED lights (5%-100%)

02. WS002-PIR

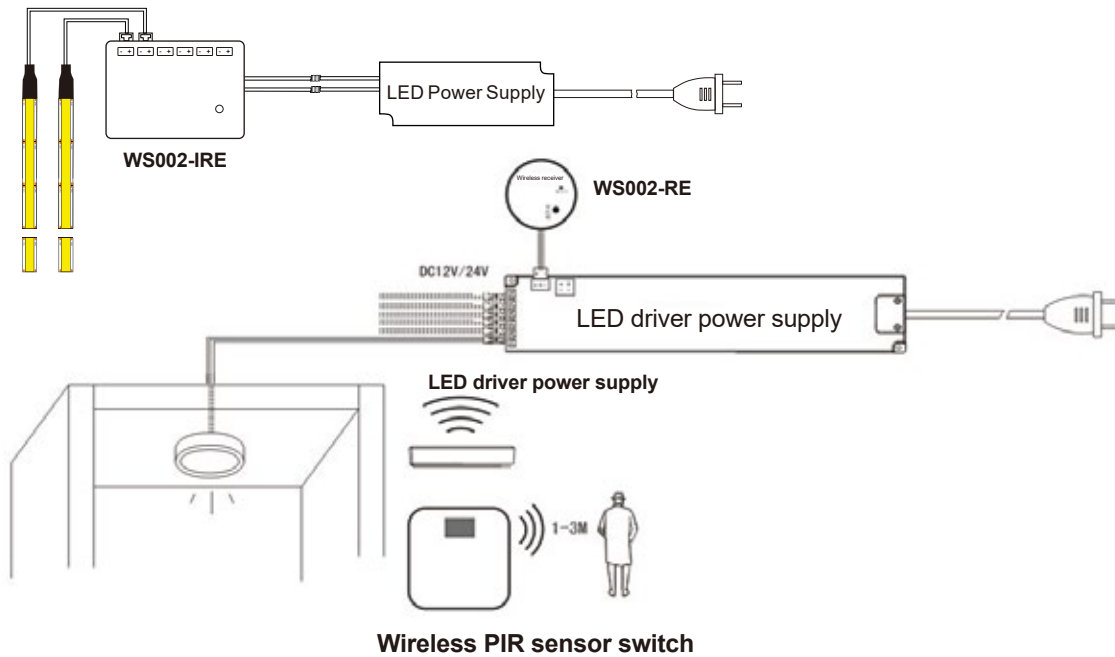

WS002-PIR Working Mode

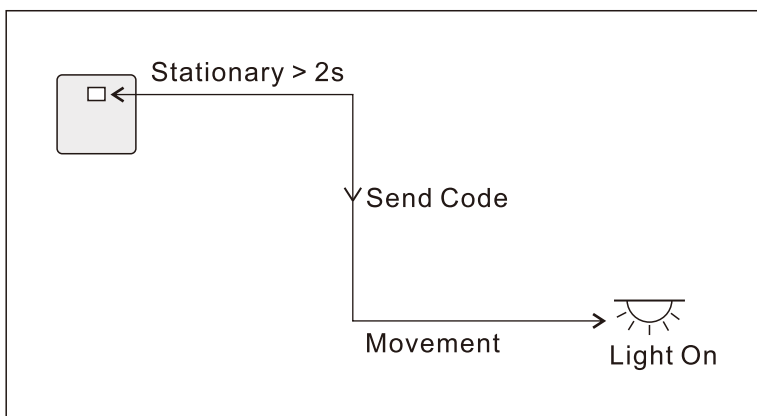

Sensing Window

Can Be Repeatedly Triggered

1. Introduction to the PIR sensor function: When a human body movement is detected within the detection range of 1-3M, the wireless sensor controller switches to the ON state (ON). When the person leaves the detection range for 30 seconds, the wireless sensor controller switches to the OFF state (OFF).

03. WS002-DOOR

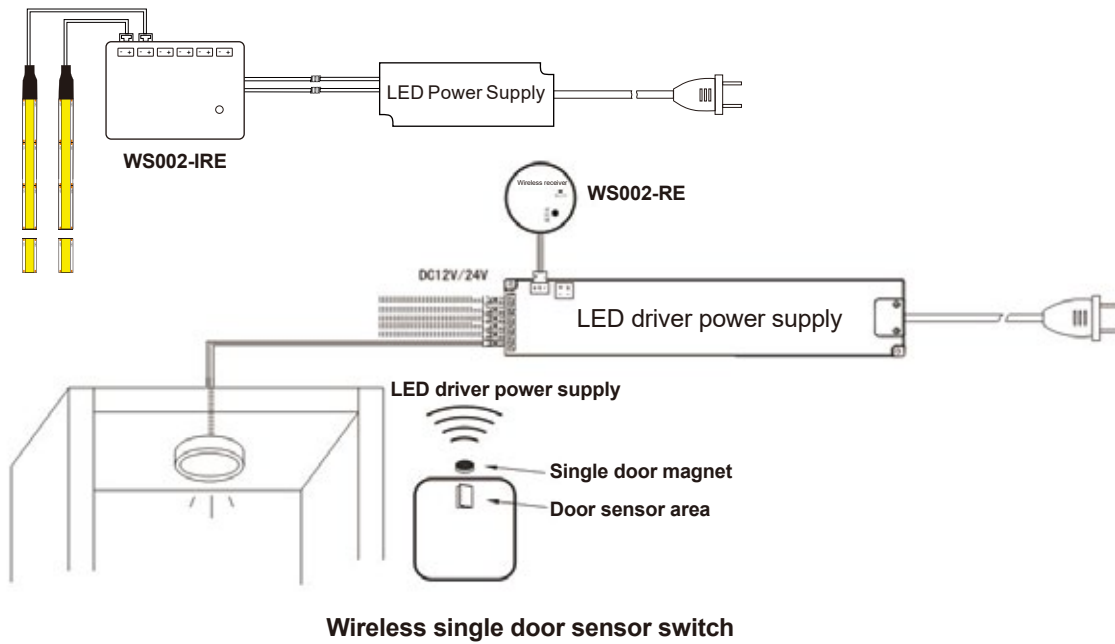

WS002-DOOR Working Mode

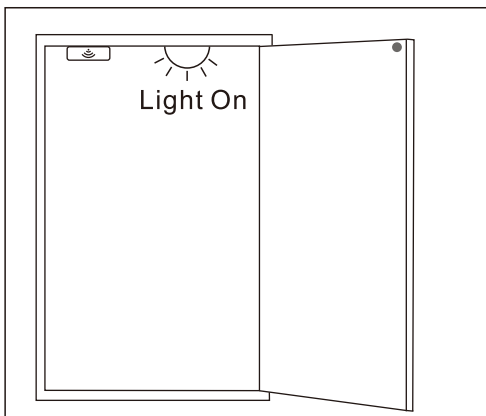

Sensing Window

Lights on when door is opened, lights off when door is closed.

Introduction to door control sensor function:

1. During assembly, the magnet must be assembled on the door sensor, otherwise the induction will fail.
2. When the door is opened, the light turns on when the magnet leaves the door magnetic induction area. When the door is closed, the light goes off when the magnet is in the door magnetic induction area.

04. WS002-2DOOR

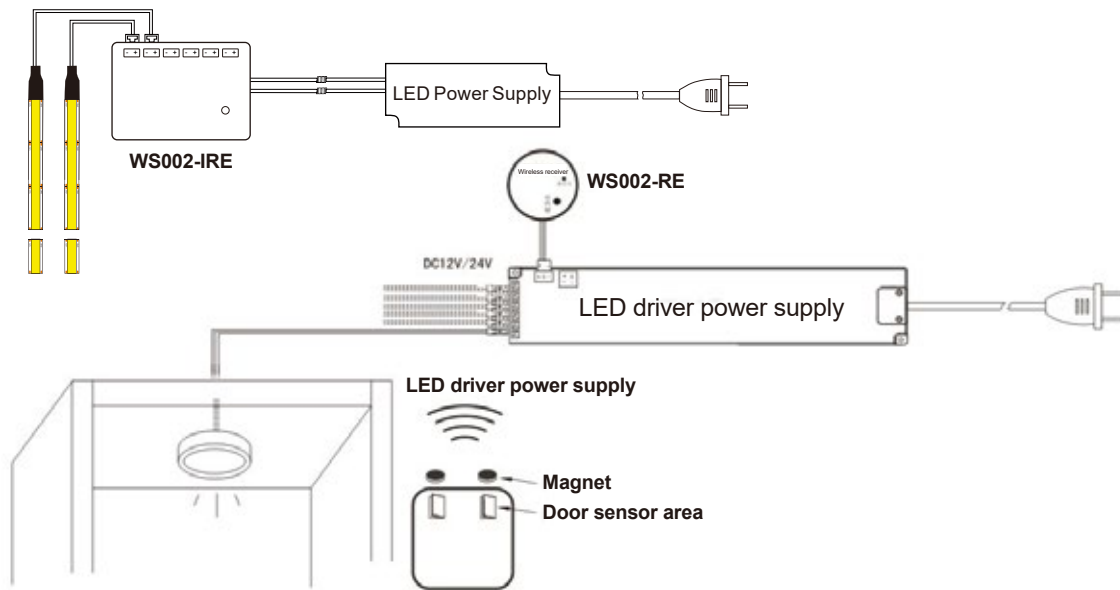

Wireless double door control sensor switch

WS002-DOOR2 Working Mode

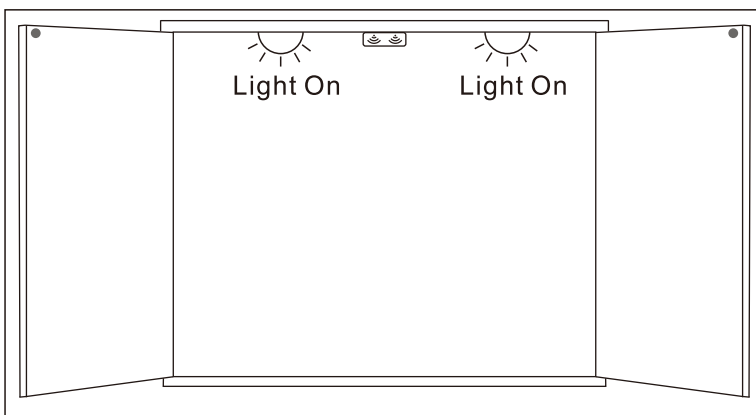

Sensing Window

Lights on when door is opened, lights off when door is closed.

Introduction to door control sensing function:

1. During assembly, the magnet must be assembled on the door sensor, otherwise the induction will fail.
2. For the double door sensor, when open one door or two doors, the light turns on when the magnet leaves the door magnetic induction area. When closing the door, the light will be off when both the two door magnets are in the door magnetic induction area.

2. Precautions

1. When the receiver is powered on, it will automatically enter the pairing mode. If the pairing code is not received within 6 seconds, it will automatically exit pairing mode, or the user can cancel the pairing and exit earlier.
2. There can only have one transmitter launching, in the same wireless coverage area, and at the same time, otherwise the receiving end will not respond.